

MDE Series
Molding Power Inductors
Size 252010

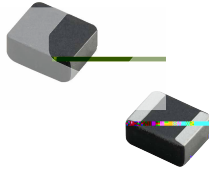

APPLICATION

- Generic in portable DC to DC converter line.
- Smart phone, PAD
- DC/DC converter
- Thin-type power supply module.

Dimensions: [mm]

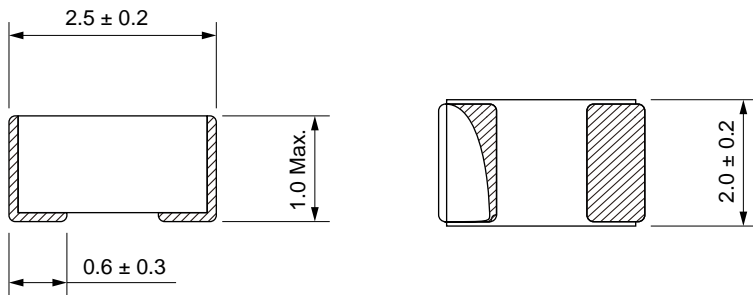

Land Pattern: [mm]

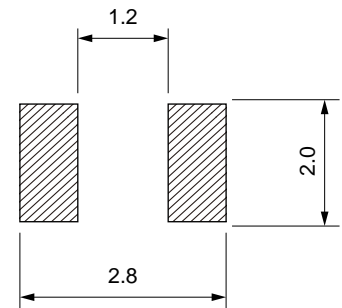

Electrical Properties:

	Inductance @ 1MHz/1V	Tolerance	DC Resistance Typ.	DC Resistance Max.	Current Typ.	Current Max.	Temperature Rise Current Typ.	Temperature Rise Current Max.
		±20%	9	12.5	7.9	7.20	5.90	5.30
		±20%	21	26.0	6.6	6.00	4.40	4.00
		±20%	27	32.0	5.0	4.50	3.90	3.51
		±20%	37	44.0	4.3	3.87	3.40	3.06
		±20%	45	54.0	3.5	3.15	3.00	2.70
		±20%	76	91.0	2.6	2.34	2.50	2.25
		±20%	99	119	2.4	2.16	2.30	2.07
		±20%	220	262	1.8	1.62	1.36	1.22



Typical Electrical Characteristics:

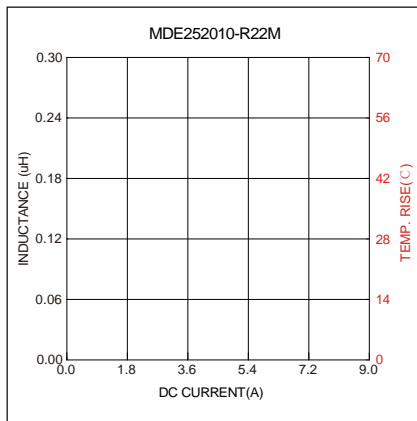

Soldering Reflow:

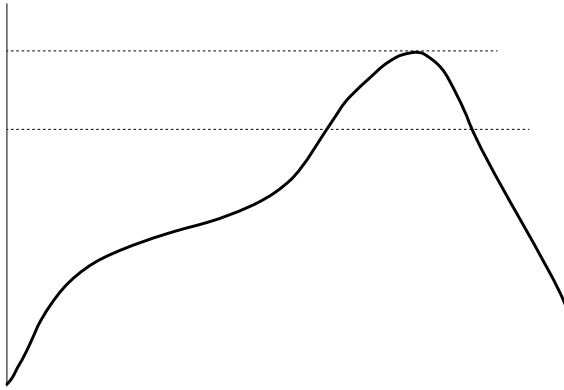

Preheat condition: 150 ~200 °C / 60~180 sec.

Allowed time above 217 °C : 60~150 sec.

Max temperature: 260 °C .

Packaging Information:

Tape Dimension:

Peel force of top cover tape:

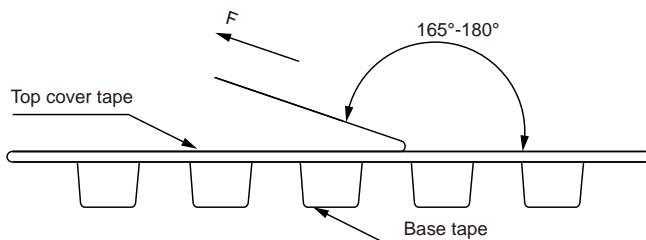

The peel force of top cover tape shall be between 0.1 to 1.3 N



Reel Dimension: [mm]

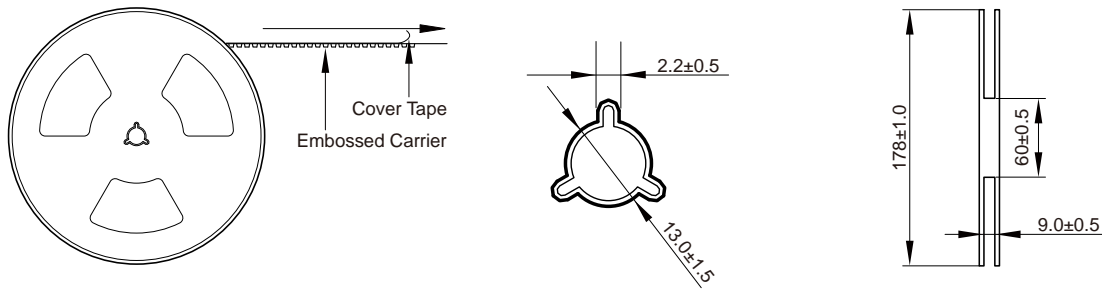

Packaging Quantity:

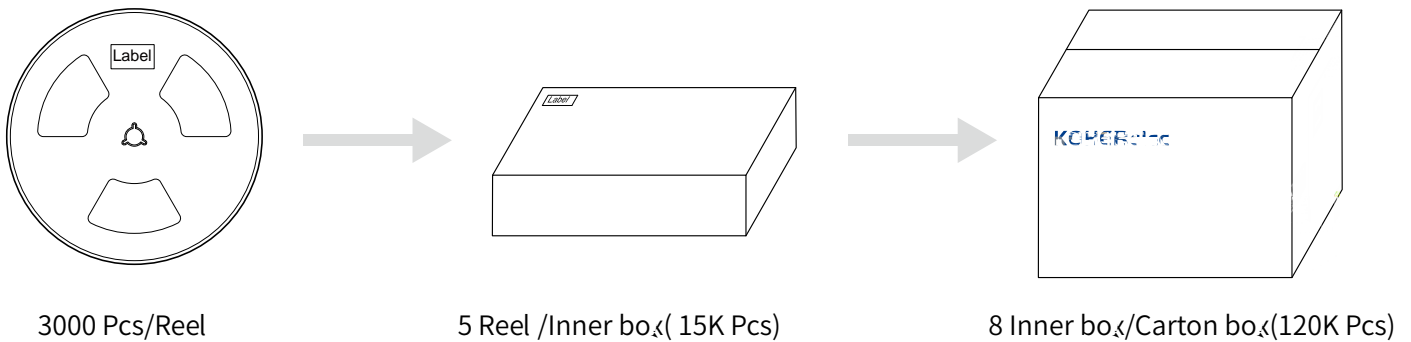

Cautions and Warnings:

Storage Conditions:

- The storage period is within 12 months after the completion of production. Be sure to follow the storage conditions (temperature: -5 to 35°C, humidity: 75% RH Max). If the storage period elapses, the soldering of the terminal electrodes may deteriorate. The warranty period is one year.
- Product should not be exposed to environment with high temperature, high humidity, dust, corrosive gas and etc.
- Products should be handled with care to avoid damage or contamination from perspiration and skin oils.
- Please always handle products carefully to prevent any damage caused by dropping down or inappropriate removing.

Operation Instructions:

- Self heating (temperature increase) occurs when the power is turned ON, so the tolerance should be sufficient for the set thermal design.
- Before soldering, be sure to preheat components. The preheating temperature should be set so that the temperature difference between the solder temperature and chip temperature does not exceed 150°C.
- Soldering corrections after mounting should be within the range of the conditions determined in the specifications. If overheated, a short circuit, performance deterioration, or lifespan shortening may occur.
- Generally, Koher might not be familiar with either customer's specific application or actual requests as customer does. As a result customer shall be responsible for checking and confirming whether Koher product with the performance described in the product specification is suitable for using in customer's particular application or not.